

SENSOR-DISINFECTANT DISPENSER WP174E-7 FOR MOUNTING BEHIND FIXED MIRROR



86 x 242 x 150 mm

950 ml tank

- Sensor disinfectant dispenser in robust, germ-reducing and easy-care stainless steel (AISI 316L).
- For mounting behind fixed mirror on site.
- With EWAR® eModule touch-free operated disinfectant pump with 950 ml tank.
- Tank with large, lockable refill opening.
- Designed for standard disinfectants. Accessible for refilling through spring stop pin and by removing from below.
- eModule battery-powered with two 1.5 V Baby/LR14 batteries. Power supply available as an option.
- Wear parts can be replaced as modules.
- Mounting: With two screws through key holes and one optional anti-theft hole in the back wall. Depth of substructure installation: min. 185 mm Height above vanity unit: min. 270 mm
- Delivery includes fixing material, batteries and self-adhesive information label „Disinfectant“.
- Weight, including single package: 1.3 kg



Suggested text for specifications:

Sensor disinfectant dispenser in stainless steel (AISI 316L) for mounting behind fixed mirror. With touch-free operated disinfectant pump with 950 ml tank. Designed for standard disinfectants. Accessible for refilling through spring stop pin and by removing from below. Delivery includes fixing material, batteries and self-adhesive information label „Disinfectant“.

Dimensions: 86 x 242 x 150 mm

Article No. WP174e-7

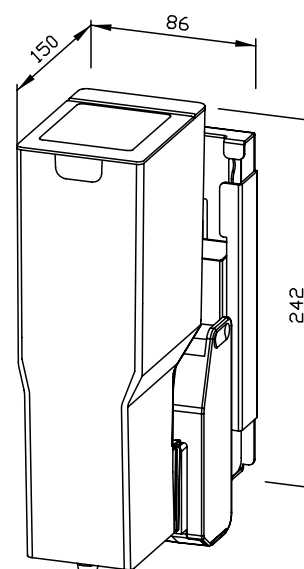

Options	ID No.
Power supply for eModule	923 060

Available surface	ID No.
satın finished	727 046

Ernst Wagner GmbH & Co. KG

Ernst-Abbe-Straße 21 · D-72770 Reutlingen · Tel.: +49712151539-0 · Fax: -20
info@wagner-ewar.de · www.wagner-ewar.de

WAGNER
EWAR